

2/2

HIGH CORROSION RESISTANT VALVES

221G SERIES

MAGNALIFT

316L STAINLESS ST. - SILVER SHADIN RING

PIPE MOUNTING

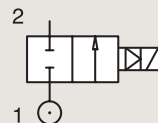

NORMALLY CLOSED

Port Size	Orifice Ø mm	Flow Factors		Operating Pressure Differential			Fluid Temperature		Seat Seal	Parker Valves			IS	ATEX Zone	Protection Mode	Power		Coil Group	Dwg N°
		Kv l/min	KV m³/h	Min. Bar	Max. (MOPD) AC bar	DC bar	Min. °C	Max. °C		Valve Ref.	Housing Ref.	Coil Ref.				AC W	DC W		
3/8"	15	65	3.90	0	16	-	-10	100	FKM	221G6306	2995	481865	-	-	-	8	-	2.0	3732
	15	65	3.90	0	20	5	-10	100	FKM	221G6306	2995	492425	-	-	-	14	14	2.0	3732
	15	65	3.90	0	16	-	-10	65	FKM	221G6306	2995	495870	-	2-22	Ex nAc nCc IIC T3/T4	8	-	2.0	3732
	15	65	3.90	0	16	-	-10	120	FKM	221G6306	4270	481000	-	-	-	8	-	2.0	3732
	15	65	3.90	0	20	7	-10	140	FKM	221G6306	4270	486265	-	-	-	14	14	2.0	3732
	15	65	3.90	0	16	-	-10	80	FKM	221G6306	-	495905	-	1-21	Ex db mb IIC T4	8	-	2.0	3732
	15	65	3.90	0	-	10	-10	100	FKM	221G6336 ₁	2995	481865	-	-	-	-	9	2.1	3732
	15	65	3.90	0	-	10	-10	65	FKM	221G6336 ₁	2995	495870	-	2-22	Ex nAc nCc IIC T3/T4	-	9	2.1	3732
	15	65	3.90	0	10	10	-10	65	FKM	221G6336 ₁	-	492070	-	1-21	Ex mb IIC T4/T5	9	8	2.1	3732
	15	65	3.90	0	10	10	-10	75	FKM	221G6336 ₁	-	492190	-	1-21	Ex eb mb IIC T3/T4	11	9	2.1	3732
	15	65	3.90	0	-	10	-10	80	FKM	221G6336 ₁	-	495905	-	1-21	Ex db mb IIC T4	-	8	2.1	3732
	15	65	3.90	0	10	-	-10	100	EPDM	221G6307	2995	481865	-	-	-	8	-	2.0	3732
	15	65	3.90	0	10	-	-10	65	EPDM	221G6307	2995	495870	-	2-22	Ex nAc nCc IIC T3/T4	8	-	2.0	3732
	15	65	3.90	0	10	-	-10	120	EPDM	221G6307	4270	481000	-	-	-	8	-	2.0	3732
	15	65	3.90	0	10	7	-10	140	EPDM	221G6307 ₂	4270	486265	-	-	-	14	14	2.0	3732
1/2"	15	80	4.80	0	16	-	-10	100	FKM	221G6506	2995	481865	-	-	-	8	-	2.0	3732
	15	80	4.80	0	20	5	-10	100	FKM	221G6506	2995	492425	-	-	-	14	14	2.0	3732
	15	80	4.80	0	16	-	-10	65	FKM	221G6506	2995	495870	-	2-22	Ex nAc nCc IIC T3/T4	8	-	2.0	3732
	15	80	4.80	0	16	-	-10	120	FKM	221G6506	4270	481000	-	-	-	8	-	2.0	3732
	15	80	4.80	0	20	7	-10	140	FKM	221G6506	4270	486265	-	-	-	14	14	2.0	3732
	15	80	4.80	0	16	-	-10	80	FKM	221G6506	-	495905	-	1-21	Ex db mb IIC T4	8	-	2.0	3732
	15	80	4.80	0	-	10	-10	100	FKM	221G6536 ₁	2995	481865	-	-	-	-	9	2.1	3732
	15	80	4.80	0	-	10	-10	65	FKM	221G6536 ₁	2995	495870	-	2-22	Ex nAc nCc IIC T3/T4	-	9	2.1	3732
	15	80	4.80	0	10	10	-10	65	FKM	221G6536 ₁	-	492070	-	1-21	Ex mb IIC T4/T5	9	8	2.1	3732
	15	80	4.80	0	10	10	-10	75	FKM	221G6536 ₁	-	492190	-	1-21	Ex eb mb IIC T3/T4	11	9	2.1	3732
	15	80	4.80	0	-	10	-10	80	FKM	221G6536 ₁	-	495905	-	1-21	Ex db mb IIC T4	-	8	2.1	3732
	15	80	4.80	0	10	-	-10	100	EPDM	221G6507	2995	481865	-	-	-	8	-	2.0	3732
	15	80	4.80	0	10	-	-10	65	EPDM	221G6507	2995	495870	-	2-22	Ex nAc nCc IIC T3/T4	8	-	2.0	3732
	15	80	4.80	0	10	-	-10	120	EPDM	221G6507	4270	481000	-	-	-	8	-	2.0	3732
	15	80	4.80	0	10	7	-10	140	EPDM	221G6507 ₂	4270	486265	-	-	-	14	14	2.0	3732
15	80	4.80	0	10	-	-10	80	EPDM	221G6507	-	495905	-	1-21	Ex db mb IIC T4	8	-	2.0	3732	

Notes:

- Without shading ring
- Maximum pressure for steam: 4 bar (140°C)



For this page	Port size	Orifice (mm)	Kv (l/min)	MOPD (bar)	Fluid Temp (°C)
From	3/8"	15	65	6	-10
To	1/2"	15	80	20	140

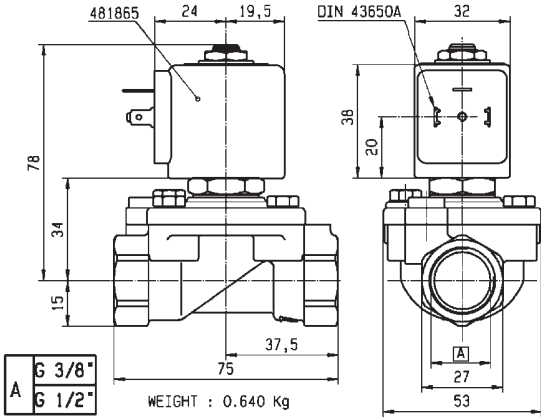

Drawing 3732